

SECTION **RAX**
REAR AXLE

A
B
C

RAX

CONTENTS

E

PRECAUTION	2	REMOVAL AND INSTALLATION	8	F
PRECAUTIONS	2	REAR WHEEL HUB AND HOUSING	8	
Precautions for Drive Shaft	2	Exploded View	8	G
PREPARATION	3	Removal and Installation	8	
PREPARATION	3	Inspection	10	
Special Service Tools	3	REAR DRIVE SHAFT	12	H
Commercial Service Tools	3	Exploded View	12	
SYMPTOM DIAGNOSIS	5	Removal and Installation	13	
NOISE, VIBRATION AND HARSHNESS		WHEEL SIDE	14	I
(NVH) TROUBLESHOOTING	5	WHEEL SIDE : Disassembly and Assembly	14	
NVH Troubleshooting Chart	5	FINAL DRIVE SIDE	16	J
PERIODIC MAINTENANCE	6	FINAL DRIVE SIDE : Disassembly and Assembly....	17	
REAR WHEEL HUB AND HOUSING	6	Inspection	19	
Inspection	6	SERVICE DATA AND SPECIFICATIONS		K
REAR DRIVE SHAFT	7	(SDS)	20	
Inspection	7	SERVICE DATA AND SPECIFICATIONS		L
		(SDS)	20	
		Wheel Bearing	20	M
		Drive Shaft	20	

F
G
H
I
J
K
L
M
N
O
P

PRECAUTIONS

< PRECAUTION >

PRECAUTION

PRECAUTIONS

Precautions for Drive Shaft

INFOID:000000006884757

- Observe the following precautions when disassembling and assembling drive shaft.
 - Never disassemble joint sub-assembly because it is non-overhaul parts.
 - Perform work in a location which is as dust-free as possible.
 - Clean the parts, before disassembling and assembling.
 - Prevent the entry of foreign objects during disassembly of the service location.
 - Reassemble disassembled parts carefully in the correct order. If work is interrupted, a clean cover must be placed over parts.
 - Use paper waste. Fabric shop cloths must not be used because of the danger of lint adhering to parts.
 - Clean disassembled parts (except for rubber parts) with kerosene which shall be removed by blowing with air or wiping with paper waste.

PREPARATION

< PREPARATION >

PREPARATION

PREPARATION

Special Service Tools

INFOID:0000000006884758

The actual shapes of Kent-Moore tools may differ from those of special service tools illustrated here.

Tool number (Kent-Moore No.) Tool name	Description
KV40107300 (-) Boot band crimping tool	Installing boot band
KV38106700 (J-34296) Protector a: 36 mm (1.42 in) dia.	Installing drive shaft (VQ37VHR)
KV38105500 (J-33904) Protector a: 40 mm (1.57 in) dia.	Installing drive shaft (VK56VD)

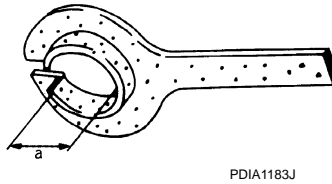
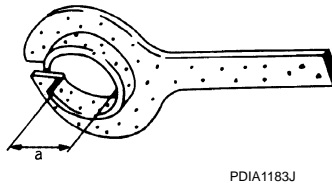
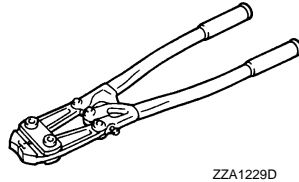

Commercial Service Tools

INFOID:0000000006884759

Tool name	Description
Power tool	Loosening bolts and nuts
Ball joint remover	<ul style="list-style-type: none"> • Removing ball joint for suspension arm • Removing hub bolt

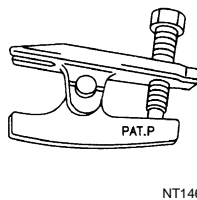
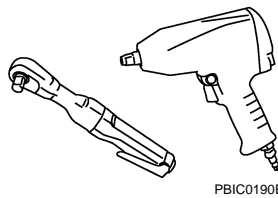

PREPARATION

< PREPARATION >

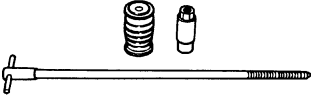
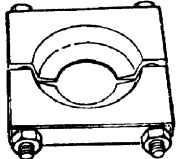
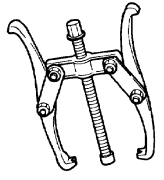
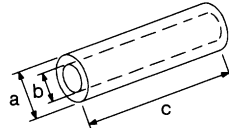
Tool name	Description
<p>Drive shaft puller</p>  <p>JPDIG0152ZZ</p>	<p>Removing drive shaft joint sub assembly</p>
<p>Replacer</p>  <p>ZZA0700D</p>	<p>Removing sensor rotor</p>
<p>Puller</p>  <p>ZZA0119D</p>	<p>Removing sensor rotor</p>
<p>Drift</p> <p>a: Approx. 85 mm (3.35 in) dia. b: 73 – 75 mm (2.87 – 2.95 in) dia. c: 125 mm (4.92 in) or more</p>  <p>S-NT117</p>	<p>Installing sensor rotor</p>

NOISE, VIBRATION AND HARSHNESS (NVH) TROUBLESHOOTING

< SYMPTOM DIAGNOSIS >

SYMPTOM DIAGNOSIS

NOISE, VIBRATION AND HARSHNESS (NVH) TROUBLESHOOTING

NVH Troubleshooting Chart

INFOID:000000006884760

Use chart below to find the cause of the symptom. If necessary, repair or replace these parts.

Symptom		Possible cause and SUSPECTED PARTS											Reference				
		Excessive joint angle	Joint sliding resistance	Imbalance	Improper installation, looseness	Parts interference	PROPELLER SHAFT	DIFFERENTIAL	REAR AXLE AND REAR SUSPENSION	REAR AXLE	TIRE	ROAD WHEEL		DRIVE SHAFT	BRAKE	STEERING	
DRIVE SHAFT	Noise	x	x				x	x	x	x	x						—
	Shake	x		x			x		x	x	x						RAX-19, "Inspection"
REAR AXLE	Noise				x	x	x	x	x		x	x	x	x			—
	Shake				x	x	x		x		x	x	x	x			—
	Vibration				x	x	x		x		x		x				RAX-8, "Exploded View"
	Shimmy				x	x			x		x	x		x			—
	Judder				x				x		x	x		x			—
	Poor quality ride or handling				x	x			x		x	x					

x: Applicable

A
B
C
RAX
E
F
G
H
I
J
K
L
M
N
O
P

REAR WHEEL HUB AND HOUSING

< PERIODIC MAINTENANCE >

PERIODIC MAINTENANCE

REAR WHEEL HUB AND HOUSING

Inspection

INFOID:000000006884761

MOUNTING INSPECTION

Make sure the mounting conditions (looseness, back lash) of each component and component conditions (wear, damage) are normal.

WHEEL BEARING INSPECTION

- Move wheel hub and bearing assembly in the axial direction by hand. Make sure there is no looseness of wheel bearing.

Axial end play : Refer to [RAX-20, "Wheel Bearing"](#).

- Rotate wheel hub and bearing assembly and make sure that is no unusual noise or other irregular conditions. If there is any of irregular conditions, replace wheel hub and bearing assembly.

REAR DRIVE SHAFT

< PERIODIC MAINTENANCE >

REAR DRIVE SHAFT

Inspection

INFOID:000000006884762

- Check drive shaft mounting point and joint for looseness and other damage.
- Check boot for cracks and other damage.

CAUTION:

Replace entire drive shaft assembly when noise or vibration occurs from drive shaft.

A

B

C

RAX

E

F

G

H

I

J

K

L

M

N

O

P

REAR WHEEL HUB AND HOUSING

< REMOVAL AND INSTALLATION >

REMOVAL AND INSTALLATION

REAR WHEEL HUB AND HOUSING

Exploded View

INFOID:000000006884763

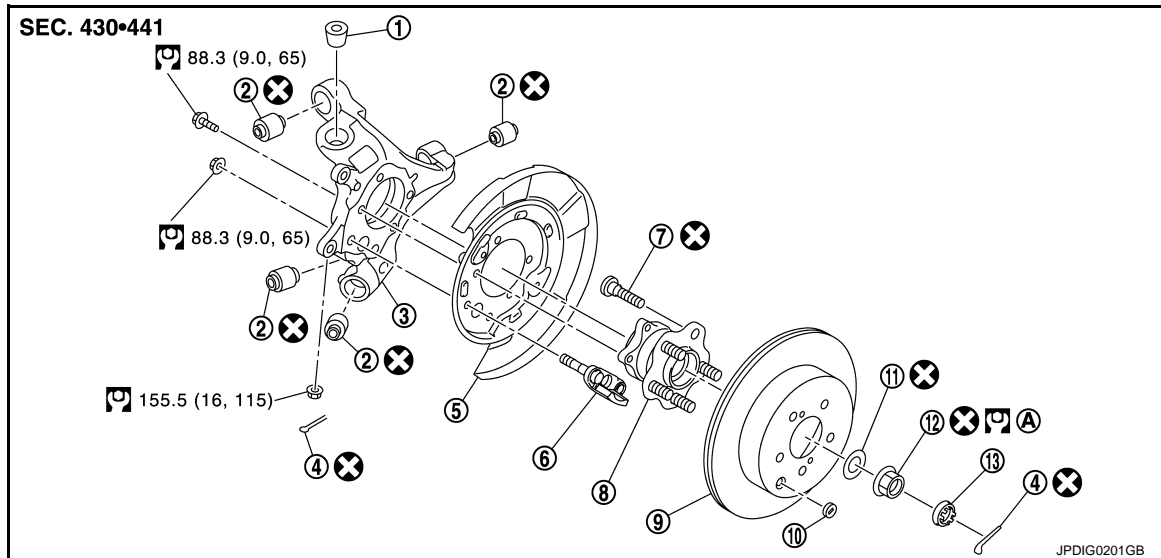

- | | | |
|-------------------|-----------------------------------|------------------------|
| 1. Ball seat | 2. Bushing | 3. Axle housing |
| 4. Cotter pin | 5. Back plate | 6. Anchor block |
| 7. Hub bolt | 8. Wheel hub and bearing assembly | 9. Disc rotor |
| 10. Plug | 11. Spring washer | 12. Wheel hub lock nut |
| 13. Adjusting cap | | |

A. Tightening must be done following the installation procedure. Refer to [RAX-8. "Removal and Installation"](#).

Refer to [GI-4. "Components"](#) for symbols in the figure.

Removal and Installation

INFOID:000000006884764

REMOVAL

Wheel Hub and Bearing Assembly

1. Remove tire from vehicle with power tool. Refer to [WT-56. "Exploded View"](#).
2. Remove caliper assembly. Hang caliper assembly in a place where it will not interfere with work. Refer to [BR-57. "BRAKE CALIPER ASSEMBLY \(1 PISTON TYPE\) : Removal and Installation"](#) (1 piston type), [BR-61. "BRAKE CALIPER ASSEMBLY \(2 PISTON TYPE\) : Removal and Installation"](#) (2 piston type).
CAUTION:
Never depress brake pedal while brake caliper is removed.
3. Remove disc rotor. If disc rotor cannot be removed, remove as follows.
CAUTION:
 - Parking brake completely in the released position.
 - Put matching marks on the wheel hub and bearing assembly and the disc rotor before removing the disc rotor.
 - Never drop disc rotor.
- a. Fix the disc rotor with wheel nuts and remove the adjusting hole plug.

REAR WHEEL HUB AND HOUSING

< REMOVAL AND INSTALLATION >

- b. Using suitable tool, rotate adjuster (1) in the direction (A) to retract and loosen brake shoe.
4. Remove parking brake shoe and parking brake cable from back plate. Refer to [PB-8, "Removal and Installation"](#) and [PB-6, "Removal and Installation"](#).

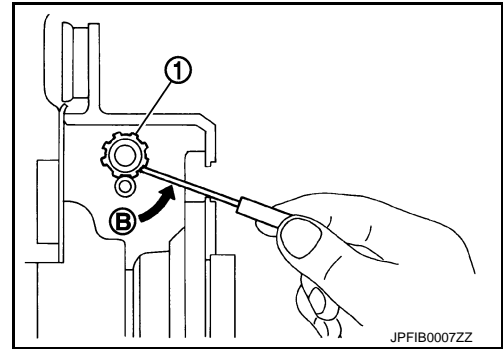

5. Set suitable jack under axle housing.
CAUTION:
Check that jack supporting status is stable.
6. Remove shock absorber from axle housing with power tool. Refer to [RSU-8, "Removal and Installation"](#).
7. Remove toe control link from axle housing. (Without 4WAS) Refer to [RSU-18, "Removal and Installation"](#).
8. Remove 4WAS rear actuator assembly from axle housing. (With 4WAS) Refer to [STC-176, "Removal and Installation"](#).
9. Remove rear lower link from axle housing side. Refer to [RSU-16, "Removal and Installation"](#).
10. Remove front lower link from axle housing side. Refer to [RSU-14, "Removal and Installation"](#).
11. Remove height sensor from suspension arm (left side). (With AFS) Refer to [EXL-116, "Removal and Installation"](#).

12. Remove stabilizer connecting rod from suspension arm. Refer to [RSU-20, "Removal and Installation"](#).
13. Remove cotter pin and adjusting cap, then loosen wheel hub lock nut with a power tool.

14. Put matching mark (A) on drive shaft and wheel hub and bearing assembly.

CAUTION:

Use paint or similar substance for matching marks. Never scratch the surface.

15. Patch wheel hub lock nut with a piece of wood. Hammer the wood to disengage wheel hub and bearing assembly from drive shaft. Take out the wheel hub lock nut and spring washer.

CAUTION:

- **Never place drive shaft joint at an extreme angle. Also be careful not to overextend slide joint.**
- **Never allow drive shaft to hang down without support for counterpart such as joint sub-assembly, and other parts.**

NOTE:

Use a suitable puller, if the wheel hub and bearing assembly and drive shaft cannot be separated even after performing the above procedure.

16. Remove wheel hub lock nut and spring washer.
17. Remove drive shaft from axle housing.
18. Remove cotter pin, then loosen suspension arm mounting nut of axle housing.
19. Separate suspension arm from axle housing, using ball joint remover, and then remove axle housing from the vehicle.

CAUTION:

- **Never damage ball joint boot.**
- **Temporarily tighten nuts to prevent damage to threads and to prevent the ball joint remover from coming off.**
- **Never place drive shaft joint at an extreme angle. Also be careful not to overextend slide joint.**
- **Never allow drive shaft to hang down without support for counterpart such as joint sub-assembly, and other parts.**

20. Remove axle housing.
21. Remove wheel hub and bearing assembly.
22. Remove anchor block and back plate.

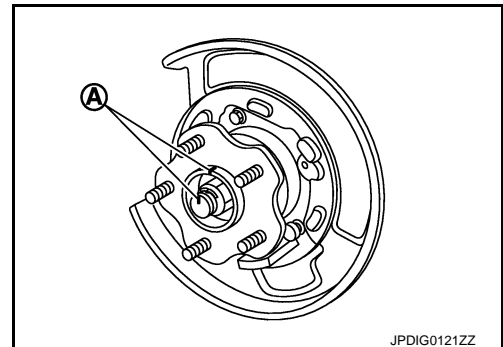

A

B

C

RAX

E

F

G

H

I

J

K

L

M

N

O

P

REAR WHEEL HUB AND HOUSING

< REMOVAL AND INSTALLATION >

23. Remove hub bolts from wheel hub and bearing assembly, using the ball joint remover (A) (commercial service tool).

CAUTION:

- Remove hub bolt only when necessary.
- Never hammer the hub bolt to avoid impact to the wheel hub and bearing assembly.
- Pull out the hub bolt in a direction perpendicular to the wheel hub and bearing assembly.

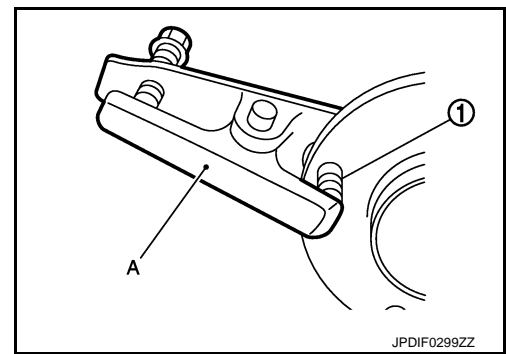

INSTALLATION

Note the following, and install in the reverse order of removal.

- Place a washer (A) as shown in the figure to install the hub bolts (1) by using the tightening force of the nut (B).

CAUTION:

- Check that there is no clearance between wheel hub and bearing assembly, and hub bolt.
- Never reuse hub bolt.
- Clean the matching surface of wheel hub lock nut and wheel hub and bearing assembly.

CAUTION:

Never apply lubricating oil to these matching surface.

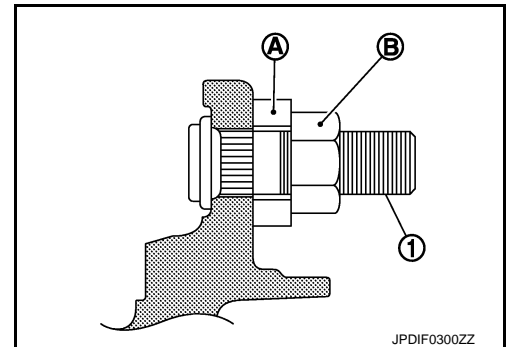

- Clean the matching surface of drive shaft and wheel hub and bearing assembly. And then apply paste [service parts (440037S000)] to surface (A) of joint sub-assembly of drive shaft.

CAUTION:

Apply paste to cover entire flat surface of joint sub-assembly of drive shaft.

Amount paste **1.0 – 3.0 g (0.04 – 0.10 oz)**

- When installing drive shaft, change the drive shaft and wheel hub and bearing assembly matching marks put at the removal step by 180 degree.
- Use the following torque range for tightening the wheel hub lock nut.

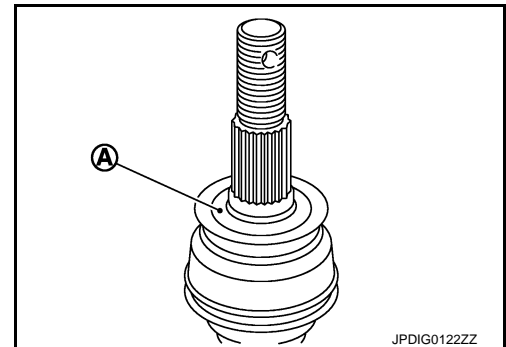

 : **100 – 105 N·m (10 – 11 kg·m, 74 – 77 ft·lb)**

CAUTION:

- Since the drive shaft is assembled by press-fitting, use the tightening torque range for the wheel hub lock nut.
- Be sure to use torque wrench to tighten the wheel hub lock nut. Never use a power tool.

NOTE:

Wheel hub lock nut tightening torque does not over torque for avoiding axle noise, and does not less than torque for avoiding looseness.

- Perform the final tightening of each of parts under unladen conditions, which were removed when removing wheel hub and bearing assembly and axle housing.
- When installing the spring washer, face the identification paint mark to the wheel hub and bearing assembly side.
- When installing the adjusting cap, check that there must be no play.
- Never reuse cotter pin, wheel hub lock nut, spring washer, and bushing.

Inspection

INFOID:000000006884765

INSPECTION AFTER REMOVAL

REAR WHEEL HUB AND HOUSING

< REMOVAL AND INSTALLATION >

Wheel Hub and Bearing Assembly

Check the wheel hub and bearing assembly for wear, cracks, and damage. Replace if necessary.

A

Axle Housing

Check the axle housing for wear, cracks, and damage. Replace if necessary.

B

Ball Joint Inspection

Check for boot breakage, axial looseness, and torque of suspension arm ball joint. Refer to [RSU-12, "Inspection and Adjustment"](#).

C

INSPECTION AFTER INSTALLATION

1. Adjust parking brake operation (stroke). Refer to [PB-3, "Inspection and Adjustment"](#).
2. Check wheel alignment. Refer to [RSU-6, "Inspection"](#).
3. Adjust neutral position of steering angle sensor. Refer to [BRC-59, "Work Procedure"](#).
4. Adjust levelizer adjustment of height sensor. (With AFS) Refer to [EXL-52, "LEVELIZER ADJUSTMENT: Special Repair Requirement"](#).

RAX

E

F

G

H

I

J

K

L

M

N

O

P

REAR DRIVE SHAFT

< REMOVAL AND INSTALLATION >

REAR DRIVE SHAFT

Exploded View

INFOID:000000006884766

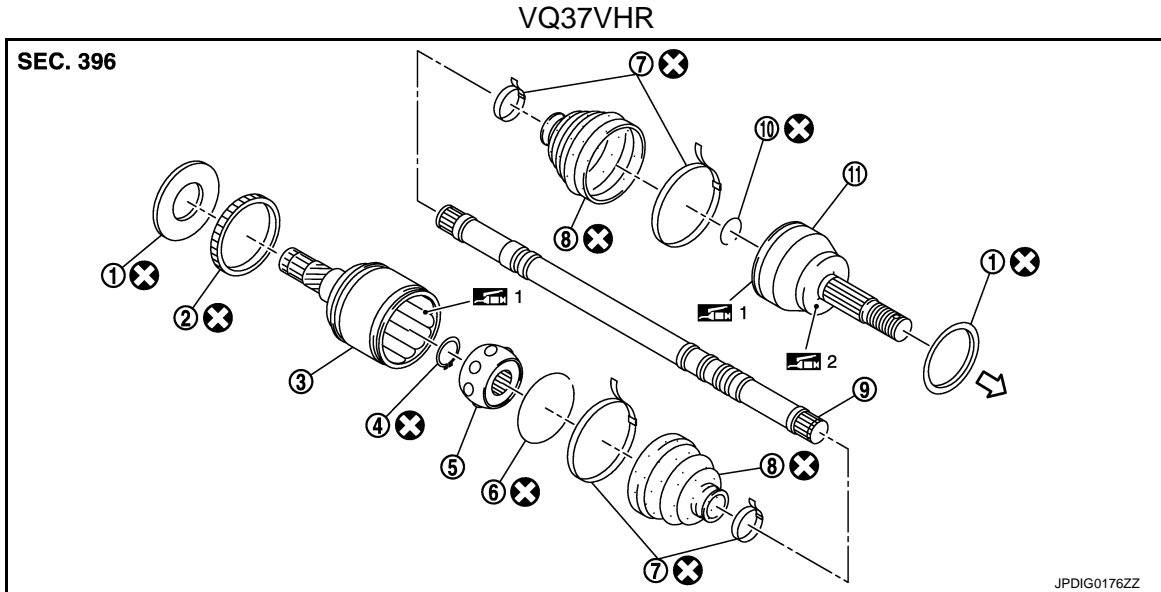

- | | | |
|-------------------|---|-----------------|
| 1. Dust shield | 2. Sensor rotor | 3. Housing |
| 4. Stopper ring | 5. Ball cage/steel ball/inner race assembly | 6. Stopper ring |
| 7. Boot band | 8. Boot | 9. Shaft |
| 10. Circular clip | 11. Joint sub-assembly | |

↶: Wheel side

1: NISSAN genuine grease or an equivalent.

2: Apply paste [service parts (440037S000)].

Refer to [GI-4, "Components"](#) for symbols not described on the above.

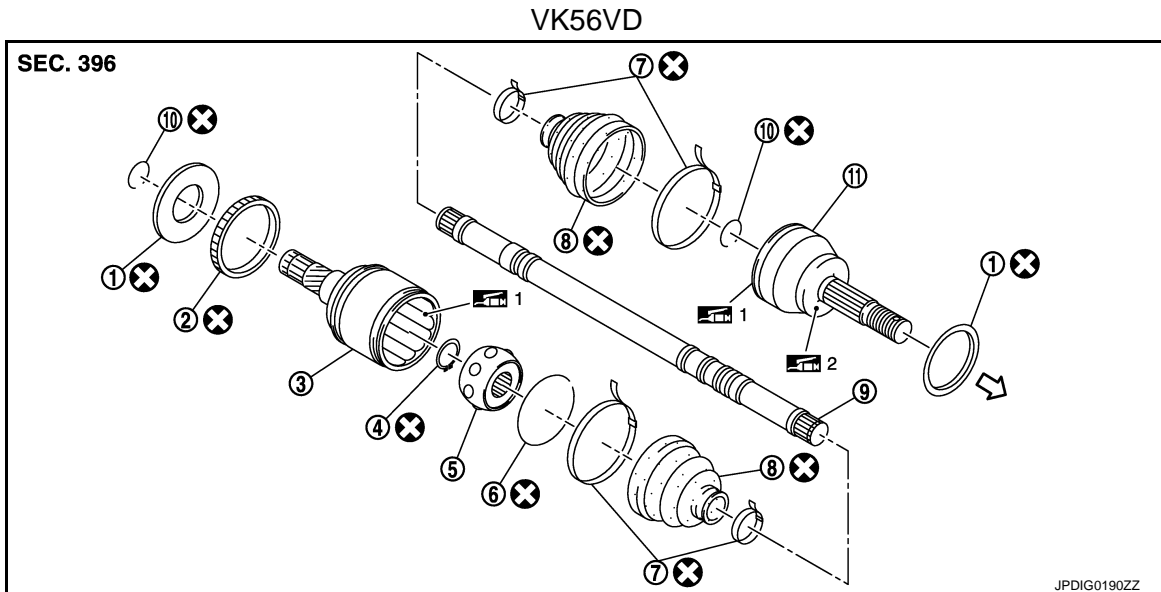

- | | | |
|-----------------|---|-----------------|
| 1. Dust shield | 2. Sensor rotor | 3. Housing |
| 4. Stopper ring | 5. Ball cage/steel ball/inner race assembly | 6. Stopper ring |
| 7. Boot band | 8. Boot | 9. Shaft |

REAR DRIVE SHAFT

< REMOVAL AND INSTALLATION >

- 10. Circular clip
- 11. Joint sub-assembly

Wheel side

1: NISSAN genuine grease or an equivalent.

2: Apply paste [service parts (440037S000)].

Refer to [GI-4. "Components"](#) for symbols not described on the above.

Removal and Installation

INFOID:000000006884767

REMOVAL

1. Remove tire from vehicle with power tool. Refer to [WT-56. "Exploded View"](#).
2. Remove center muffler. Refer to [EX-6. "VQ37VHR : Removal and Installation"](#) (VQ37VHR) or [EX-7. "VK56VD : Removal and Installation"](#) (VK56VD).
3. Remove rear propeller shaft. Refer to [DLN-97. "Removal and Installation"](#) (2WD) or [DLN-106. "Removal and Installation"](#) (AWD).
4. Remove stabilizer bar. Refer to [RSU-20. "Removal and Installation"](#).
5. Remove wheel sensor. Refer to [BRC-138. "REAR WHEEL SENSOR : Removal and Installation"](#).
6. Separate drive shaft from rear final drive assembly.

CAUTION:

Never damage sensor rotor.

NOTE:

Release the circular clip lock.

7. Remove rear final drive assembly. Refer to [DLN-170. "Removal and Installation"](#) (VQ37VHR) or [DLN-208. "Removal and Installation"](#) (VK56VD).
8. Remove cotter pin and adjusting cap, then loosen wheel hub lock nut with power tool.

9. Put matching mark (A) on drive shaft and wheel hub and bearing assembly.

CAUTION:

Use paint or similar substance for matching marks. Never scratch the surface.

10. Patch wheel hub lock nut with a piece of wood. Hammer the wood to disengage wheel hub and bearing assembly from drive shaft.

NOTE:

Using a suitable puller if the wheel hub and bearing assembly and drive shaft cannot be separated even after performing the above procedure.

11. Remove wheel hub lock nut and spring washer.
12. Remove drive shaft from axle housing.

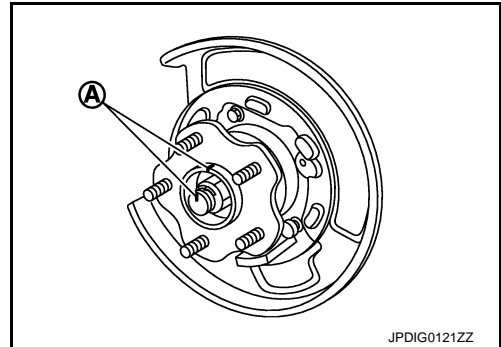

INSTALLATION

Wheel Side

Note the following, and install in the reverse order of removal.

- Clean the matching surface of wheel hub lock nut and wheel hub and bearing assembly.

CAUTION:

Never apply lubricating oil to these matching surface.

A
B
C
RAX
E
F
G
H
I
J
K
L
M
N
O
P

REAR DRIVE SHAFT

< REMOVAL AND INSTALLATION >

- Clean the matching surface of drive shaft and wheel hub and bearing assembly. And then apply paste [service parts (440037S000)] to surface (A) of joint sub-assembly of drive shaft.

CAUTION:

Apply paste to cover entire flat surface of joint sub-assembly of drive shaft.

Amount paste 1.0 – 3.0 g (0.04 – 0.10 oz)

- When installing drive shaft, change the drive shaft and wheel hub and bearing assembly matching marks put at the removal step by 180 degree.
- Use the following torque range for tightening the wheel hub lock nut.

 : **100 – 105 N·m (10 – 11 kg·m, 74 – 77 ft·lb)**

CAUTION:

- **Since the drive shaft is assembled by press-fitting, use the tightening torque range for the wheel hub lock nut.**

- **Be sure to use torque wrench to tighten the wheel hub lock nut. Never use a power tool.**

NOTE:

Wheel hub lock nut tightening torque does not over torque for avoiding axle noise, and does not less than torque for avoiding looseness.

- Perform the final tightening of each of parts under unladen conditions, which were removed when removing wheel hub and bearing assembly and axle housing.
- When installing the spring washer, face the identification paint mark to the wheel hub and bearing assembly side.
- When installing the adjusting cap, check that there must be no play.
- Never reuse cotter pin, wheel hub lock nut, and spring washer.

Final Drive Side

- Replace rear final drive side oil seal. Refer to [DLN-169, "Removal and Installation"](#) (VQ37VHR) or [DLN-207, "Removal and Installation"](#) (VK56VD).
- Place the protector (A) [SST: KV38106700 (J-34296)] (VQ37VHR) or [SST: KV38105500 (J-33904)] (VK56VD) onto final drive to prevent damage to the oil seal while inserting drive shaft. Slide drive shaft sliding joint and tap with a hammer to install securely.

CAUTION:

Check that circular clip is completely engaged.

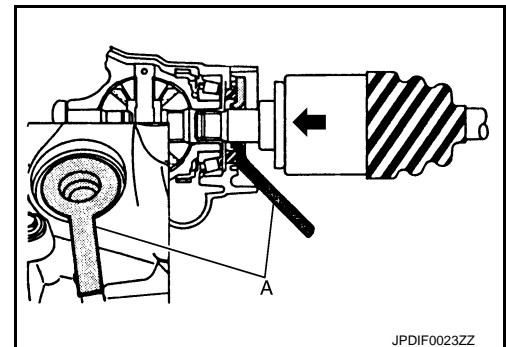
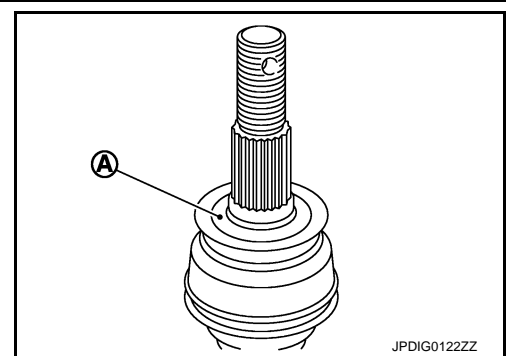

WHEEL SIDE

WHEEL SIDE : Disassembly and Assembly

INFOID:000000006884768

DISASSEMBLY

1. Fix shaft with a vise.

CAUTION:

Protect shaft when fixing with a vise using aluminum or copper plates.

2. Remove dust shield from joint sub-assembly.
3. Remove boot bands and then remove boot from joint sub-assembly.

REAR DRIVE SHAFT

< REMOVAL AND INSTALLATION >

- Screw the drive shaft puller (A) (commercial service tool) 30 mm (1.18 in) or more into the thread of joint sub-assembly, and remove joint sub-assembly from shaft.

CAUTION:

- If joint sub-assembly cannot be removed after five or more unsuccessful attempts, replace shaft and joint sub-assembly as a set.
- Align sliding hammer and drive shaft and remove them by pulling directory.

- Remove circular clip from shaft.
- Remove boot from shaft.

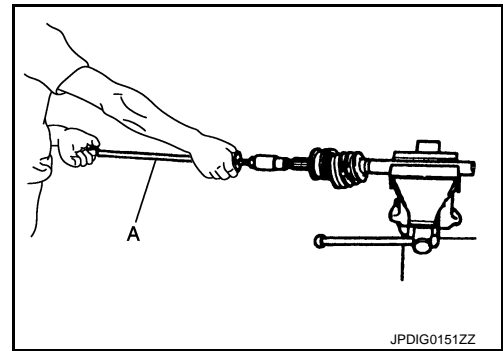

JPDIG0151ZZ

ASSEMBLY

- Clean old grease on joint sub-assembly with paper waste.
- Fill serration slot joint sub-assembly (1) with NISSAN genuine grease or equivalent until the serration slot and ball groove become full to the brim.

CAUTION:

After applying grease, use a shop cloth to wipe off old grease that has oozed out.

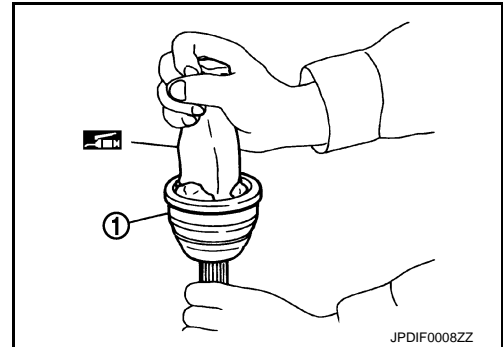

JPDIF0008ZZ

- Install boot and boot bands to shaft.

CAUTION:

- Wrap serration on shaft with tape (A) to protect the boot from damage.
- Never reuse boot and boot band.

- Remove the tape wrapped around the serrated on shaft.
- Position circular clip on groove at the shaft edge.

CAUTION:

Never reuse circular clip.

NOTE:

Drive joint inserter is recommended when installing circular clip.

- Align both center axes of the shaft edge and joint sub-assembly. Then assemble shaft with circular clip joint sub-assembly.
- Install joint sub-assembly to shaft using plastic hammer.

CAUTION:

Confirm that joint sub-assembly is correctly engaged while rotating drive shaft.

- Apply the balance of the specified amount of grease into the boot inside from large diameter side of boot.

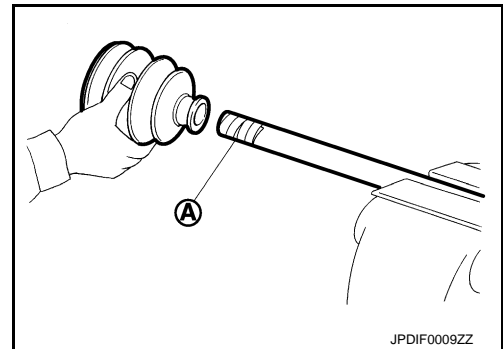

JPDIF0009ZZ

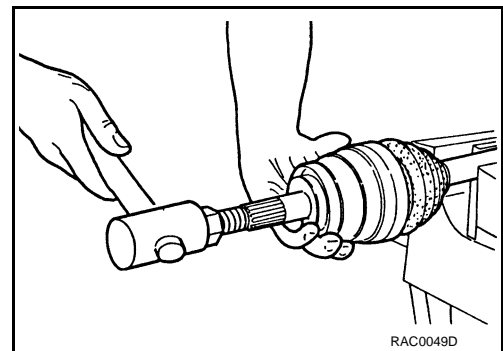

RAC0049D

Grease amount : Refer to [RAX-20, "Drive Shaft"](#).

- Install the boot securely into grooves (indicated by "*" marks) shown in the figure.

REAR DRIVE SHAFT

< REMOVAL AND INSTALLATION >

- VQ37VHR

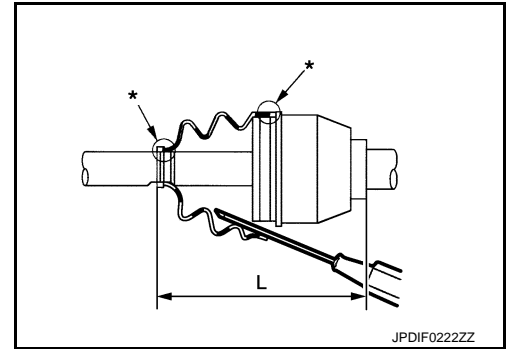

- VK56VD

CAUTION:

If grease adheres to the boot mounting surface (indicated by “*” mark) on the shaft or housing, boot may come off. Remove all grease from the surfaces.

- To prevent the deformation of the boot, adjust the boot installation length (L) to the specified value shown below by inserting the suitable tool into inside of the boot from the large diameter side of boot and discharging the inside air.

L : Refer to [RAX-20, "Drive Shaft"](#).

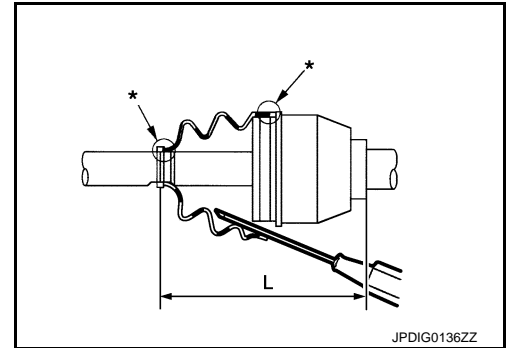

CAUTION:

- If the boot installation length is outside the standard, it may cause breakage of the boot.
- Be careful not to touch the inside of the boot with the tip of tool.

- Secure the ends of the boot with boot bands using the boot band crimping tool (A) [SST: KV40107300 (-)].

CAUTION:

- Never reuse boot band.

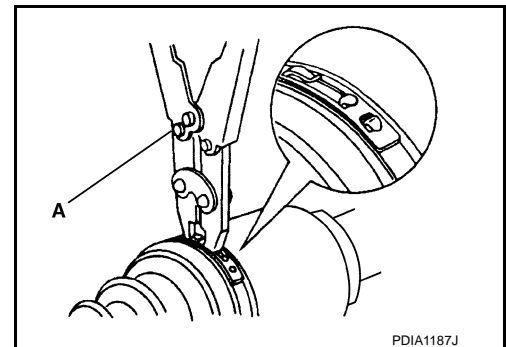

- Secure boot band so that dimension (M) meets the specification as shown in the figure.

M : 2.0 – 3.0 mm (0.079 – 0.118 in)

- Secure joint sub-assembly and shaft, and then make sure that they are in the correct position when rotating boot. Install them with boot band when boot installation positions become incorrect.

CAUTION:

Never reuse boot band.

- Install dust shield to joint sub-assembly.

CAUTION:

Never reuse dust shield.

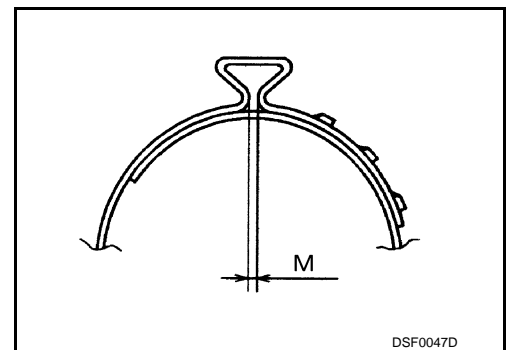

FINAL DRIVE SIDE

REAR DRIVE SHAFT

< REMOVAL AND INSTALLATION >

FINAL DRIVE SIDE : Disassembly and Assembly

INFOID:000000006884769

DISASSEMBLY

1. Fix shaft with a vise.

CAUTION:

Protect shaft when fixing with a vise using aluminum or copper plates.

2. Remove circular clip from housing. (VK56VD)
3. Remove dust shield from housing.
4. Remove sensor rotor from housing, using a replacer (commercial service tool) and a puller (commercial service tool).
5. Remove boot bands, and then remove boot from housing.
6. Put matching marks on housing and shaft.

CAUTION:

Use paint or similar substance for matching marks. Never scratch the surface.

7. Remove stopper ring with suitable tool, and pull out housing.
8. Put matching marks on ball cage/steel ball/inner race assembly and shaft.

CAUTION:

Use paint or similar substance for matching marks. Never scratch the surface.

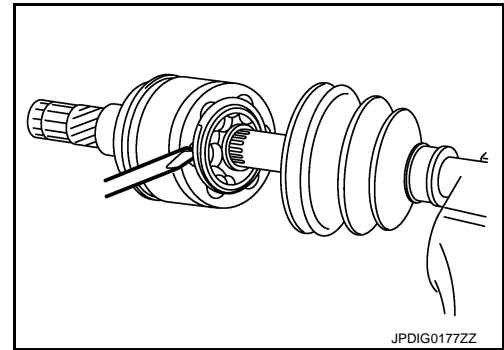

9. Remove snap ring, then remove ball cage/steel ball/inner race assembly from shaft.
10. Remove boot from shaft.

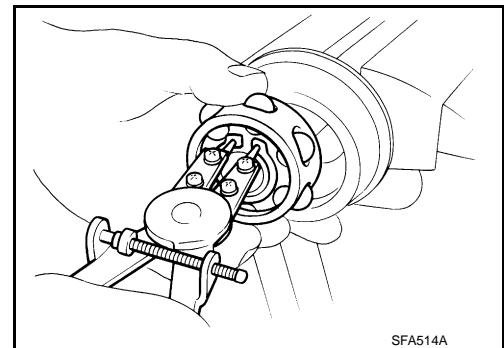

ASSEMBLY

1. Remove old grease on housing with paper waste.
2. Install sensor rotor (1) to housing, using a drift (A) (commercial service tool).

CAUTION:

Never reuse sensor rotor.

3. Install boot and boot bands to shaft.

CAUTION:

- Wrap serration shaft with tape (A) to protect the boot from damage.
- Never reuse boot and boot band.

4. Remove the tape wrapped around the serrated on shaft.

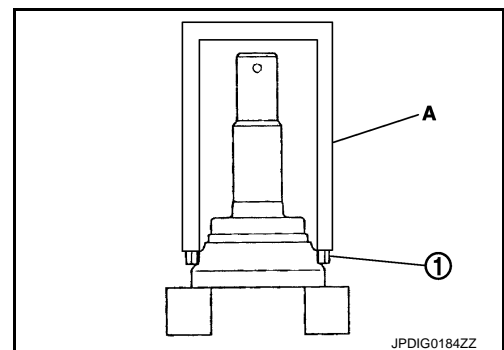

A
B
C
RAX
E
F
G
H
I
J
K
L
M
N
O
P

REAR DRIVE SHAFT

< REMOVAL AND INSTALLATION >

5. Install ball cage/steel ball/inner race assembly (1), align it with the matching marks on shaft (2) put during the removal.
6. Secure ball cage/steel ball/inner race assembly onto shaft with snap ring (3).

CAUTION:

Never reuse snap ring.

7. Apply the appropriate amount of grease onto housing and sliding surface.

Grease amount : Refer to [RAX-20, "Drive Shaft"](#).

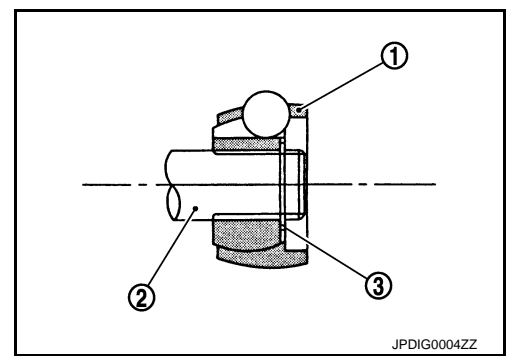

8. Install housing.
 9. Install stopper ring to housing.
- CAUTION:**
Never reuse stopper ring.
10. After installed, pull shaft to check engagement between housing and stopper ring.
 11. Install boot securely into grooves (indicated by "*" marks) shown in the figure.
 - VQ37VHR

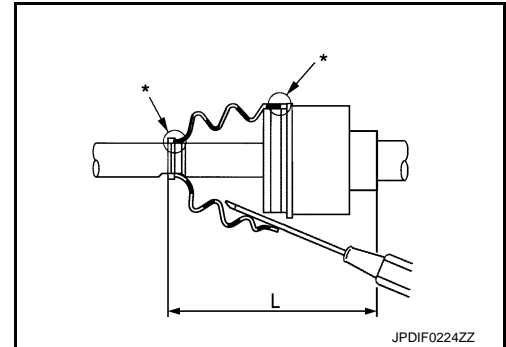

- VK56VD

CAUTION:

If grease adheres to the boot mounting surfaces (indicated by "*" marks) on shaft or housing, boot may be removed. Remove all grease from the surfaces.

12. To prevent the deformation of the boot, adjust the boot installation length (L) to the value shown below by inserting the suitable tool into the inside of boot from the large diameter side of boot and discharging inside air.

L : Refer to [RAX-20, "Drive Shaft"](#).

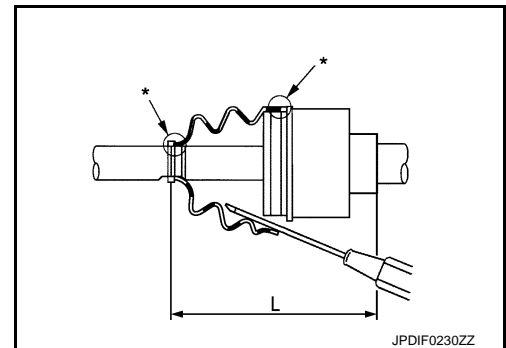

CAUTION:

- If the boot installation length is outside the standard, it may cause breakage of the boot.
- Be careful not to touch the inside of the boot with the tip of tool.

13. Install boot bands securely as shown in the figure.

CAUTION:

Never reuse boot band.

14. Check that location stays in the correct position when housing and shaft are secured and boot is rotated.

CAUTION:

- Install again when location does not stay in the correct position.
- Never reuse boot band.

15. Install circular clip to housing. (VK56VD)

CAUTION:

Never reuse circular clip.

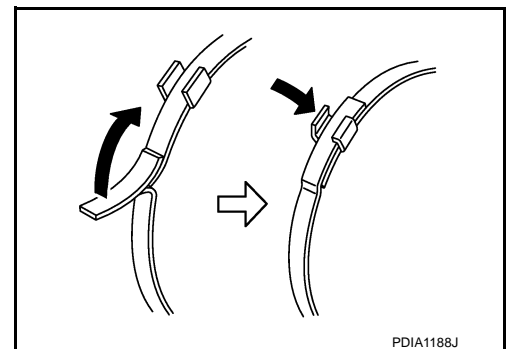

REAR DRIVE SHAFT

< REMOVAL AND INSTALLATION >

16. Install dust shield to housing.

CAUTION:

Never reuse dust shield.

Inspection

INFOID:000000006884770

INSPECTION AFTER REMOVAL

- Move joint up/down, left/right, and in the axial direction. Check for any rough movement or significant looseness.
- Check boot for cracks or other damage, and also for grease leakage.
- If a malfunction is found, disassemble drive shaft, and then replace with new one.
- Check sensor rotor for cracks or other damage.

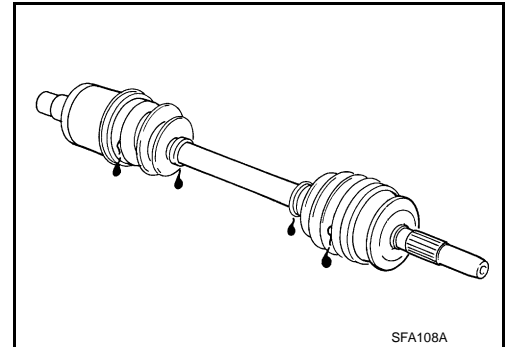

INSPECTION AFTER ASSEMBLY

Check sensor rotor for cracks or other damage.

A

B

C

RAX

E

F

G

H

I

J

K

L

M

N

O

P

SERVICE DATA AND SPECIFICATIONS (SDS)

< SERVICE DATA AND SPECIFICATIONS (SDS)

SERVICE DATA AND SPECIFICATIONS (SDS)

SERVICE DATA AND SPECIFICATIONS (SDS)

Wheel Bearing

INFOID:000000006884771

Item	Standard
Axial end play	0.05 mm (0.002 in) or less

Drive Shaft

INFOID:000000006884772

Item		Standard	
		Wheel side	Final drive side
Grease quantity	VQ37VHR	110 – 120 g (3.88 – 4.23 oz)	124 – 134 g (4.37 – 4.73 oz)
	VK56VD	110 – 130 g (3.88 – 4.58 oz)	115 – 135 g (4.06 – 4.76 oz)
Boots installed length	VQ37VHR	150.7 mm (5.93 in)	197.5 mm (7.78 in)
	VK56VD	136.1 mm (5.36 in)	196.3 mm (7.73 in)